



UNA-CLAD™ SERIES 1000 Composite Wall Panel System

DESCRIPTION:

The UNA-CLAD Series 1000 panel system is designed to utilize an Architectural Composite Material (ACM) face skin. A variety of material and finish options are available. The Series 1000 panels utilize rout-and-return fabrication. Panel clips are mechanically fastened from the panel to the wall sub-straight. The Series 1000 panel system is designed as a caulked barrier wall panel system.

METHOD OF APPLICATION:

1. Attachment of panels to a system of subgirts or direct attachment to a smooth, solid substrate of plywood is recommended for the Firestone Series 1000 panels.
2. Series 1000 panels are to be installed as needed; non-sequential installation of system.
3. Application of a Firestone approved weather resistant barrier prior to panel installation is required.
4. Panel installation occurs via the field installation of the Firestone wall panel clip. Basic installation is two fasteners from the clip into the wall panel and one fastener from the clip (through the slotted hole) into the substraight.

Note: Follow approved shop drawing installation details.

STORAGE:

1. Stored in a well ventilated, dry place where no moisture can contact the panels. Moisture (from rain, snow, condensation, etc.) trapped between layers of material may cause water stains or white rust, which can affect the service life of the material and will detract from its appearance.
2. If outdoor storage cannot be avoided, protect the panels with a ventilated canvas or waterproof paper cover. Do not use plastic, which can cause condensation. Keep the material off the ground in an inclined position with an insulator such as wood, or keep panels crated. Protective film may degrade or become brittle with exposure to direct sunlight.

PRECAUTIONS:

1. Oil canning is not a cause for rejection.
2. Exercise caution when lifting, moving, transporting, storing or handling Firestone metal to avoid possible physical damage.
3. Immediately remove protective film after installation.

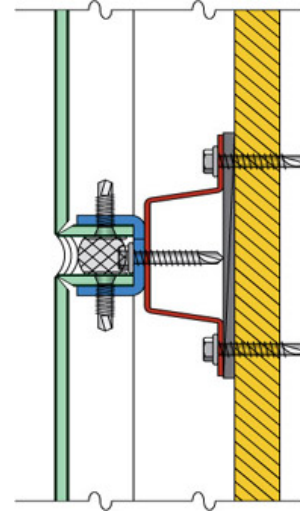

PRODUCT DATA

Panel Type:	Composite Wall Panel
Material Options:	4-mm and 6-mm material thickness
Color:	More than 53 standard colors available through a network of ACM Suppliers
Finish:	Kynar 500®/Hylar 5000™ high performance fluorocarbon resinous coatings
Optional Finish:	Anodized & Natural Metals
Sealant:	Perimeter Sealant Dow 756 with primer or Momentive SCS2000 with primer
Clip:	Field Attached
Substrate:	Subgirt System or Plywood
Standard Panel Surface:	Smooth
Optional Panel Surface:	Natural Metal

PANEL SIZE

Max Panel Width:	60" (1,524 mm)
Min. Panel Width:	1" (25.4 mm)
Max Panel Length:	194" (4,927.6 mm)
Min. Panel Length:	1" (25.4 mm)

TECHNICAL INFORMATION SHEET

2009
01/08/09



UNA-CLAD™ SERIES 1000 Composite Wall Panel System

Manufacturing Facilities: Anoka, MN
Reno, NV

TECHNICAL INFORMATION

Air Infiltration:	ASTM E283-91
Structural Performance:	ASTM E330-90*
Water Penetration:	ASTM E331-93
Bond Integrity:	ASTM D1781-76**
Bond Durability:	ASTM C481 Cycle B**
BOCA Evaluation:	No 93-57**
Fire Resistance:	ASTM E84 Class "A" Rating**
Vibration / Sound Dampening:	ASTM E756-83**
ICBO Evaluation Report:	No PCF-4909**
New York City MEA:	75-91-M, 390-99-M**
Los Angeles Research Report:	RR 25121, RR 25285**

Finish Testing Available:
Contact FSMP for Technical Information Sheets on Finishes

*Testing not applicable for all substrates, materials, and dimensions. All systems with test listings must be installed in accordance with assembly tested

**Testing on ACM materials available through network of ACM manufacturers.

This sheet is meant only to highlight Firestone's products and specifications. Information subject to change without notice. Firestone takes responsibility for furnishing quality materials, which meet Firestone's published product specification. As neither Firestone itself nor its representatives practice architecture, Firestone offers no opinion on, and expressly disclaims any responsibility for the soundness of any structure on which its products may be applied. If questions arise as to the soundness of a structure, or its ability to support a planned installation properly, the Owner should obtain opinions of competent structural engineers before proceeding. Firestone accepts no liability for any structural failure or for resultant damages, and no Firestone representative is authorized to vary the disclaimer.

Firestone Metal Products Company, LLC
1001 Lund Blvd. Anoka, MN 55303
Phone: 763-576-9595 • Fax: 763-576-9596
Toll Free: 800-426-7737
<http://www.unaclad.com>