



UNA-CLAD™ SC-2 Laminated Sunscreen System

DESCRIPTION:

The UNA-CLAD™ SC-2 exterior laminated aluminum screen system is functional and enhances a building's appearance. An extensive selection of extruded bullnose options is available. Angled blades block direct sunlight and reduce interior thermal heating while allowing rain and snow to pass through easily. Blades may be set to any angle and spaced as specified. Outriggers arm profiles may be customized. The blades are mechanically attached to outriggers. Multiple wall attachment options are available. Choose from standard offerings or customize sunscreen to a specific building.

METHOD OF APPLICATION:

1. Attachment of SC-2 sunscreen to window, curtainwall frame or structural element of the building.
2. Install SC-2 sunscreen units according to Firestone Metal Products Design and Application Guides found on the Firestone website.
3. Follow approved shop drawing installation details.

STORAGE:

1. Store in a well ventilated, dry place where no moisture can contact the units. Moisture (from rain, snow, condensation, etc.) trapped between layers of material may cause water stains or white rust, which can affect the service life of the material and will detract from its appearance.
2. If outdoor storage cannot be avoided, protect the panels with a ventilated canvas or waterproof paper cover. Do not use plastic, which can cause condensation. Keep the material off the ground in an inclined position with an insulator such as wood, or keep panels crated. Protective film may degrade or become brittle with exposure to direct sunlight.

PRECAUTIONS:

1. Do not force the sunscreens into the wall opening.
2. Exercise caution when lifting, moving, transporting, storing or handling Firestone metal to avoid possible physical damage.
3. Immediately remove protective film after installation.

Firestone Metal Products Company, LLC
A subsidiary of BFS Diversified Products, LLC
1001 Lund Blvd. Anoka, MN 55303
Phone: 763-576-9595 • Fax: 763-576-9596
Toll Free: 800-426-7737
<http://www.unaclad.com>

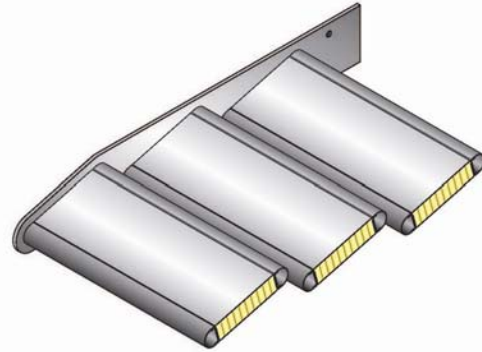

PRODUCT DATA

Sunscreen Type:	SC-2
Material Options:	.040" and .063" Aluminum Sheet .090" and .125" Extruded Aluminum 6063-T6
Color:	Choose from FSMP standard colors or have unit custom painted to desired color
Finish:	Kynar 500® /Hylar 5000™ high performance fluorocarbon resinous coating
Optional Finish:	Anodized
Mounting Bracket:	Extruded or Formed Aluminum

PANEL SIZE

Max Unit Projection:	60"
Min. Unit Projection:	10"
Max Unit Blade Size:	3" thick x 46" deep x 180" long
Min. Unit Blade Size:	1" thick x 6" deep x 12" long

TECHNICAL INFORMATION

Structural, Performance, Vibration and Sound:

Each unity is individually engineered to meet a buildings unique requirements

Finish Testing Available:

Contact FSMP for Technical Information Sheets on Finishes

Manufacturing Facilities: Anoka, MN

This sheet is meant only to highlight Firestone's products and specifications. Information subject to change without notice. Firestone takes responsibility for furnishing quality materials, which meet Firestone's published product specification. As neither Firestone itself nor its representatives practice architecture, Firestone offers no opinion on, and expressly disclaims any responsibility for the soundness of any structure on which its products may be applied. If questions arise as to the soundness of a structure, or its ability to support a planned installation properly, the Owner should obtain opinions of competent structural engineers before proceeding. Firestone accepts no liability for any structural failure or for resultant damages, and no Firestone representative is authorized to vary the disclaimer.